

ALTERNATOR

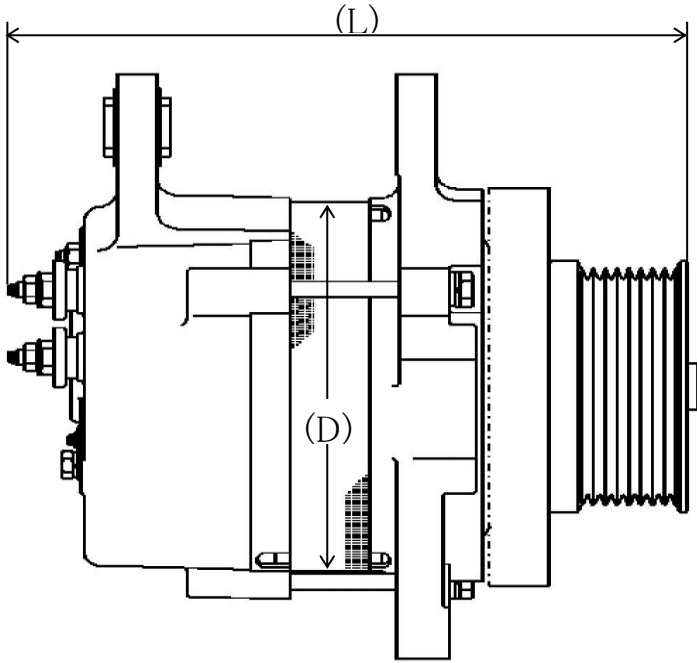

With Brush type

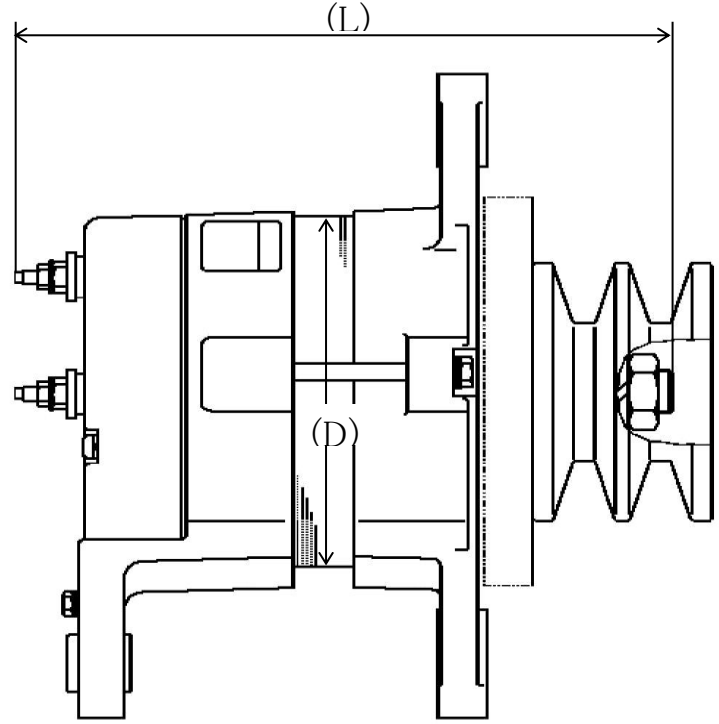

Brushless type

ALTERNATOR Specification List

Type	Rated Voltage (V)	Rated Output (AMPS)															Specification		Full Length (L) (mm)	Weight (kg)	Stator Outer Diameter (D) (mm)	Mounting Distance (mm)	Brush type	
		10	20	30	40	50	60	70	80	90	100	110	120	130	140	150	Drip-Proof	For Ships					W/Brush	Brushless
A	24			●—●													○		210.0	6.5	Φ 125	68.0	○	
B	24				●—●												○		216.0	7.5	Φ 129	100.9		○
C	24					●—●											○		206.7	8.5	Φ 130	68.5		○
D	24				●—●	●—●											○		198.0	9.0	φ 148	68.5		○
E	24					●—●										○		205.0	10.0					
F	24							●—●									○		207.0	11.0	Φ 150	68.5		○
G	24					●—●	●—●										○	○	200.0	13.0	φ 165	68.0		○
H	24							●									○		233.5	12.9	φ 168	100.9		○
I	24									●—●	●—●						○		221.0	16.5	Φ 180	100.9		○
J	24									●—●	●—●						○		216.5	19.0	Φ 200	68.0		○
K	24									●—●	●—●					○		260.0	22.5					
L	24													●			○		297.0	31.5		—		○

ALTERNATOR

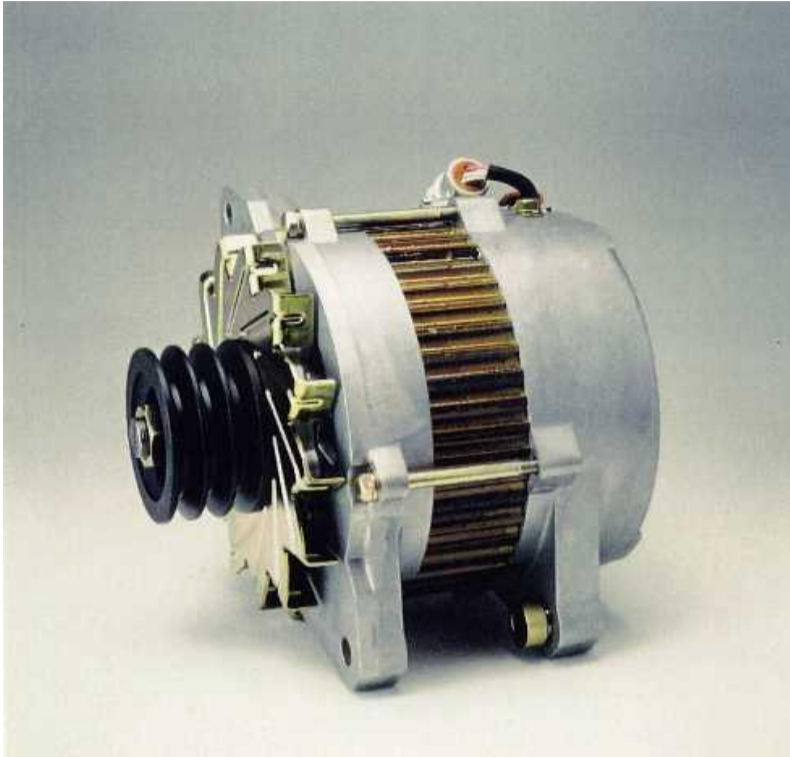

With Brush type



Brushless type

ALTERNATOR for Diesel Engine Series Table

